

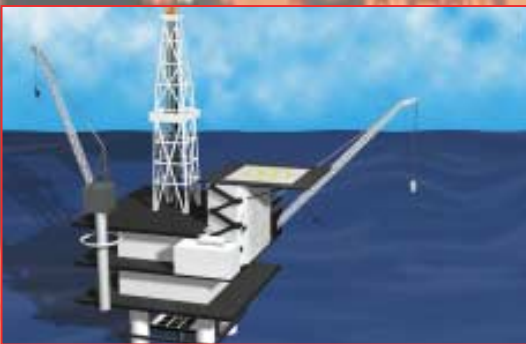

Camera - Monitor Systems

An eye for hazardous areas

**THE SMALLEST
EXPLOSION
PROOF CAMERA**
in the world



High quality color camera
with night-vision.



ORLACO explosion-proof color camera

- ▶ Orlaco explosion-proof camera-monitor systems are specifically designed to increase safety in potentially dangerous areas. By providing clear, remote visual control, Orlaco cameras can improve vision during critical operations, and reduce (even remove) the need for human presence in hazardous operations.
- ▶ Perfect vision: To enable operators to react more quickly and watch the screen for longer periods without becoming tired, Orlaco insists on high resolution systems producing a sharp and accurate image.
- ▶ No condensation or ice: To prevent the formation of condensation and ice, Orlaco cameras are equipped with 'smart' heating systems, activated automatically at temperatures below +15 degrees Celsius.
- ▶ Scratch resistant: Rugged, robust construction is key to every Orlaco design. For the highest level of scratch and chip resistance, each camera uses extra thick glass, which has been chemically hardened to 7 times harder than normal glass.
- ▶ Water resistant: When just one drop of water is enough to weaken the image, Orlaco cameras must be designed to work in all conditions. To protect against every eventuality, Orlaco cameras are filled with dry nitrogen. Every camera is resistant to the harshest conditions and guaranteed waterproof and gasproof.
- ▶ Cameras can be designed to accommodate operators' specified field of view with a 72x zoomlens. With a closely defined field of view, operators can focus attention on the critical area and react swiftly to problems without distraction. Cameras are completed with night-vision (0-lux) for clear view in dark circumstances.

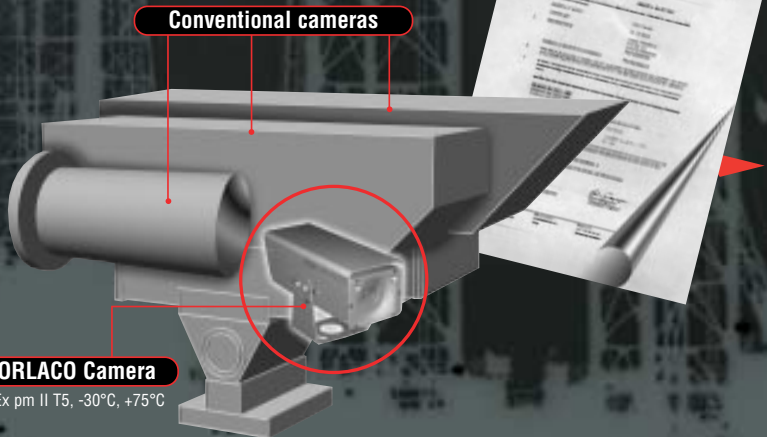

- ▶ Compact design: Compact design techniques make the Orlaco explosion-proof camera the smallest of its type anywhere in the world, allowing easy fitting in positions you never imagined possible.



The camera/monitor systems by Orlaco are entirely conform the latest CE, ADR, RFI, VDE and EMC specifications.



Ihr ORLACO Händler:

- ▶ **IEL** Tel: +43 7416 53280
- ▶ **Ing. Erwin Lestan** Fax: +43 7416 53280 88
- ▶ Anton Fahrner-Gasse 2 E-mail orlaco@iel.net
- ▶ **A-3250 WIESELBURG** Internet www.iel.net/orlaco
- ▶ **Austria** ATU 50183402